



This datasheet describes a 2-channel Gate Drive for IGBT modules (nHPD<sup>2</sup> and LinPak) in a compact form. The gate drive is suitable for use with 3300V and 1700V IGBT and SiC modules and is designed to fit within the footprint of the module to minimise the overall size of the converter.

The gate drive is qualified to international standards.

### Features

- Compatible with nHPD<sup>2</sup> and LinPak IGBT modules
- High current drive into gate: 32A source, 30A sink
- 15V input voltage
- Operating temperature range: -40°C to +85°C
- Type I and type II short circuit protection
- Power supply undervoltage protection
- LED status indication
- IGBT and gate drive temperature encoded onto the fibre-optic output
- Lead free design, RoHS compliant
- 12 months warranty

### Standards (refer to table on next page for full details)

- EN 50155 compliant for railway applications (when conformally coated)
- Thermal shock and vibration to IEC 61373
- EMC compliant to EN 50121-3-2, EN 50121-5, IEC 61800-3

### Absolute Maximum Ratings

Permanent damage may occur if the Absolute Maximum Ratings are exceeded.

Parameter	Notes	Units	Min	Typ	Max
Supply Voltage	15V input variant	V			16.5

### Power Supply Characteristics

All data refers to +25 °C unless otherwise stated

Parameter	Notes	Units	Min	Typ	Max
Nominal Supply Voltage (V <sub>DC</sub> )	A current limited supply (<2.0A) is recommended	V	14.5	15.0	15.5
Supply current	Without load, not switching, OFF	mA		80	90
Both channels switching	Operation at 3kHz into 5SNG 0450X330300 IGBT module (equivalent to ~110nF capacitor)	mA		120	

### General Electrical Characteristics

All data refers to +25 °C unless otherwise stated

Parameter	Notes	Units	Min	Typ	Max
Under-voltage lockout threshold on 15V supply	Internal power supply of gate drive	V		10.0	
Coupling capacitance	Primary to output	pF		3	5
Dielectric test voltage	50Hz AC for 10 seconds, primary to output	V <sub>rms</sub>			7400
Gate voltage (IGBT on)		V	14.5	15.0	15.5
Gate voltage (IGBT off)		V	-10.5	-10	-9.5
Turn-on gate resistance	R <sub>g(on)</sub>	Ω		1.8	
Turn-off gate resistance	R <sub>g(off)</sub>	Ω		3.9	
Soft-turn-off gate resistance	R <sub>g(soft-off)</sub>	Ω		82.0	
Gate peak current	Limited by gate resistors	A			17
DC-DC Converter Peak Power	Continuous operation with 15V input voltage	W			12
Operating voltage (V <sub>peak</sub> )	Primary to secondary side [1,2]	V			3300
Gate Monitor Time (GMT)	Time from PWM to gate voltage check	μs		80	
Gate Monitor Level	Fault if gate voltage below this level at GMT	V	13.4	13.8	14.2
Desaturation Detect Time	Time from PWM to desaturation check, type I SC	μs		7	
Desaturation Filter Delay	Delay from desaturation to turn-off, type II SC	μs		4	
Desaturation Fault Lockout	Time for which the IGBT is held off after fault	ms		17	

### Notes

- [1]: The gate drive is compatible with 3300V and 1700V modules  
 [2]: There are no transorb (TVS) diodes fitted to clamp the over-voltage during turn-off  
 [3]: The gate resistors can be changed by agreement with Amantys  
 [4]: These parameters could be changed by agreement with Amantys

## Physical Parameters

Parameter	Notes	Units	Min	Typ	Max
Length	All dimensions have a tolerance of +/- 0.5mm	mm			98
Width		mm			62
Height		mm			50
Weight		g		80	
Screw torque	Maximum torque on gate, emitter and collector	Nm			2.0

## Standards Compliance

All data refers to +25°C unless otherwise stated

Test	Notes	Test Standard
Impulse test	18 kV 1.2/50 $\mu$ s primary to output	Type test
Dielectric test	7.4 kVrms primary to output, 50 Hz, 60 sec	Type test
Partial discharge	$\geq 2.6$ kV rms extinction, <10 pC, input to output	Type test and production test
EMC Immunity		EN 50121-3-2 Rolling Stock
		EN 50121-5 Trackside
		IEC 61800-3 Variable Speed Drives
Electrostatic discharge	Air $\pm 8$ kV, contact $\pm 6$ kV, Perf Criterion B	IEC 61000-4-2
	ESD precautions must be taken when handling the core.	
Radiated immunity	10 V/m 80-2000 MHz, Perf Criterion A	IEC 61000-4-3
Fast burst immunity	$\pm 4$ kV, Perf Criterion A	IEC 61000-4-4
Surge immunity	$\pm 2$ kV, Perf Criterion B	IEC 61000-4-5
Conducted immunity	10 Vrms, Perf Criterion A	IEC 61000-4-6
Magnetic field immunity	100 A/m AC, 300 A/m DC, Perf Criterion A	IEC 61000-4-8
Damped osc. voltage	2.5 kV line-earth, Perf Criterion B	IEC 61000-4-12
Radiated emissions (E-field)	20-230/230-1000 MHz, 50/57 dB $\mu$ V/m q-pk, 3 m	EN 55011 class A, group 1
Conducted emissions	0.15-0.5/0.5-30 MHz 99/93 dB $\mu$ V/m quasi-pk	EN 55016-2-1

## General specifications

All data refers to +25°C unless otherwise stated

Parameter	Notes	Units	Min	Typ	Max
Operating temperature		°C	-40		85
Storage temperature		°C	-40		85
Humidity	Compliant to EN 50155 Railways Applications	%		85	95
	Electronic Equipment Used on Rolling Stock with conformal coating				
Material flammability rating	UL94V-0 rated				
Pollution degree	Class 2				
Maximum altitude	Derate above this: Amantys to advise	m			2000
Environmental compliance	Reach compliant				
	RoHS compliant				
Creepage	Protective separation (Mat. Grp. 2)	mm	31.3		
	Functional isolation (Mat. Grp. 2)	mm	15.6		
Clearance	Protective separation (Mat. Grp. 2)	mm	19.3		
	Functional isolation (Mat. Grp. 2)	mm	10.5		

## Power Supply Interface

Manufacturer	Required Plug Part Number
Phoenix Contact	1925692 (FKC 2,5/ 2-ST-5,08-RF)
Amantys part number	EC001150

Pin Number	
1	2
VDC	GND

## Fibre-optic Interface (see picture to identify upper and lower interfaces)

Interface	Description	Manufacturer	Part Number	Encoding
Optical input (PWM)	Receiver (Black)	Firecomms	FR50MHIR	Light ON = IGBT ON Light ON = OK, OFF = Fault
Optical output (ACK)	Transmitter (Grey)	Firecomms	FT10MHLR	

The feedback protocol on the optical output (ACK) is the Amantys compatibility mode. One ACK pulse for each PWM edge.

The gate drive and NTC temperature measurements are encoded into a Power Insight data packet (NALP frame).

The temperature measurements can be decoded by the Power Insight Adapter.

The gate drive must be receiving incoming PWM pulses and sends the data by modulating the ACK pulse width.

At power up the application software part number is sent, followed by the temperature data continuously.

This information is transmitted from the lower gate drive only.

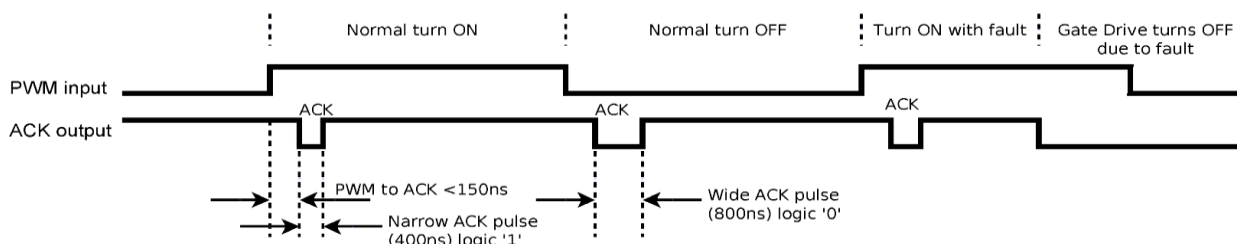

Time is measured at the gate drive and does not include propagation delay or pulse distortion of fibre-optic transceivers

## Mechanical Drawing

Please ask Amantys for 3D model (PDF or STEP file) when planning converter layout.

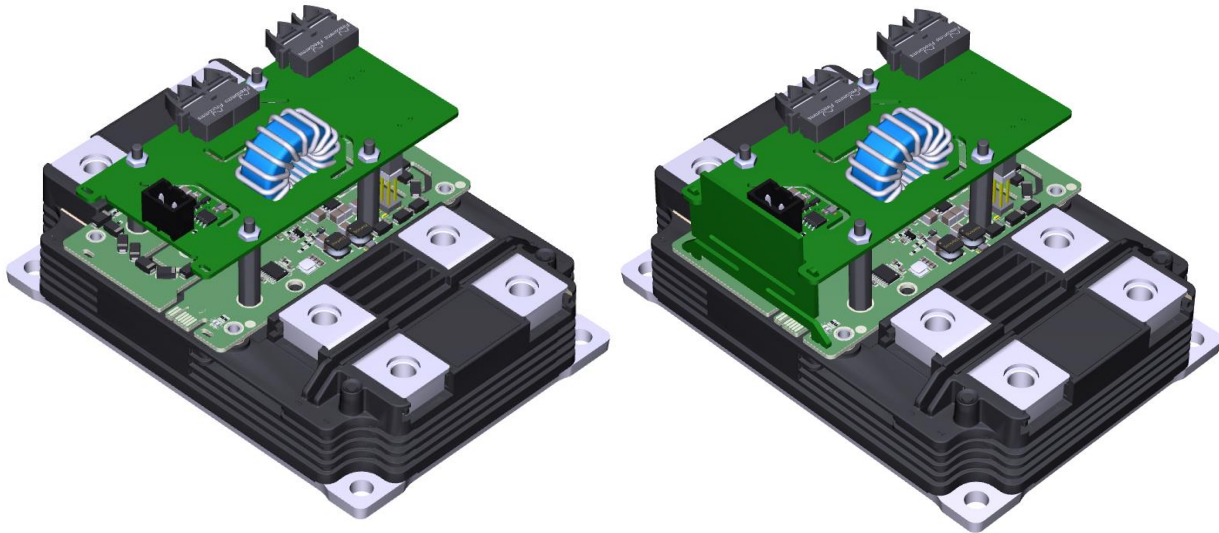

Gate Drive Assembly on IGBT Module (a) without insulator, (b) with insulator

Note: If IGBTs are mounted closer than 9mm apart then an insulator PCB can be used between gate drives to maintain clearance distance between adjacent modules.

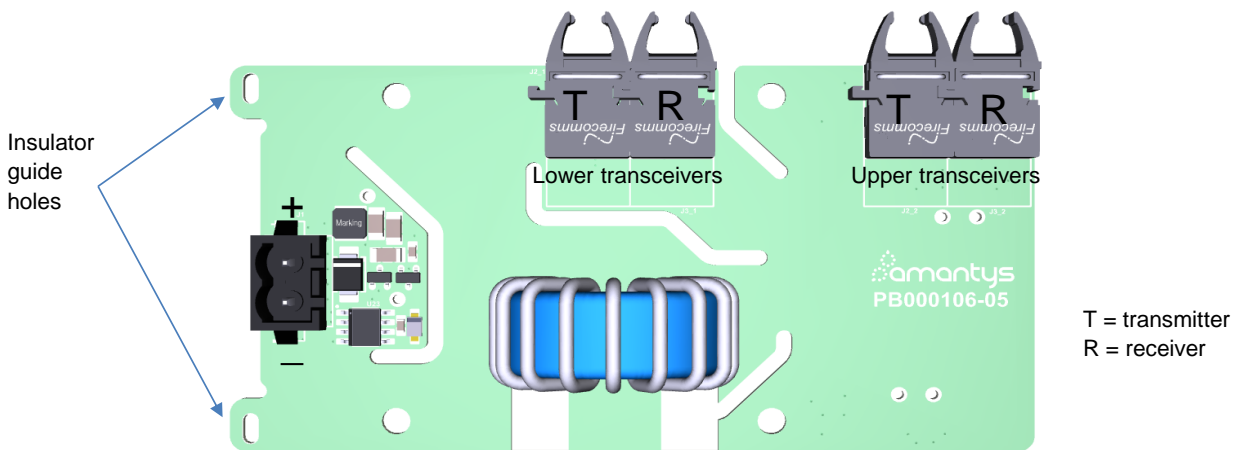

Top View of top board showing fibre-optic transceivers and power input connector

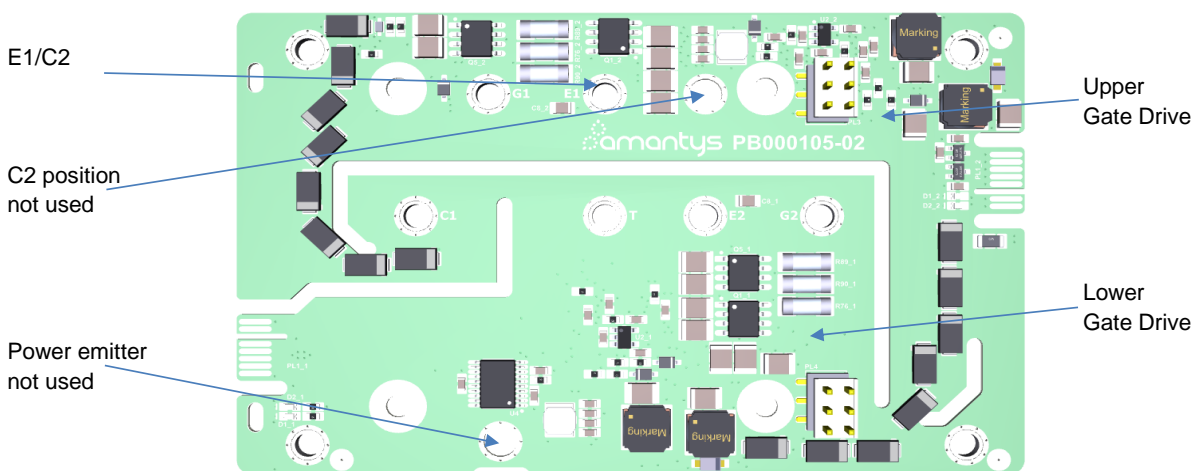

Top View of bottom board showing IGBT connections

Note: To avoid shorting copper tracks on the PCB, the screw header including any washer must not exceed the available metallic terminal pad of the bottom board. The maximum diameter is 5.6mm.

**LED Status Indication**

Each channel of the gate drive has two LEDs that communicate the status of the gate drive

LED	Behaviour	Status
Green	Lit continuously	Supply OK
Red	Lit continuously	Power supply below minimum voltage (under-voltage) or fault

When the fault is removed the red LED will stay on until the board is power cycled.

**Ordering Information**

Part Number AE00NA8SX-YYYYY or customer specific part number  
where X = 0 (uncoated) or C (coated)

YYYYY = specific part number for each configuration of resistors and PLD, e.g. 00137

**Legal Disclaimer**

This data sheet specifies devices but cannot promise to deliver any specific characteristics. No warranty or guarantee is given - either expressly or implicitly - regarding delivery, performance or suitability. Amantys Power Electronics Limited reserves the right to make modifications to its technical data and product specifications at any time and without prior notice. The general terms and conditions of delivery of Amantys Power Electronics Limited apply.

**Important Information**



The data contained herein is intended exclusively for qualified engineers who are experienced with, and trained in, working with high voltage apparatus which involves risk to life. Strict compliance with all relevant safety regulations for the target application is essential. Any handling of electronic devices is subject to the general specifications for protecting electrostatic sensitive devices according to international standard IEC 747-1, Chapter IX or European standard EN 100015 (i.e. the workplace, tool, operating environment, etc. must comply with these standards). Failure to comply may lead to the product becoming damaged.